

FLAME Arrestors

A U S T R A L I A

(A Division of Pressure Systems Pty Ltd)

KSFI Type Flame Arrestor

Explosion Proof Inline Flame Arrestor



The model KSFI Inline flame arrestor is designed, manufactured and tested according to API 2000 and British Standard Specification Code BS7244.

The units are passive devices with no moving parts.

They prevent the propagation of flame from the exposed side of the unit to the protected side by the use of a 316L stainless steel crimped metal ribbon type flame cell element.

This construction produces a matrix of uniform openings that are carefully constructed to quench the flame by absorbing the heat. This provides an extinguishing barrier to the ignited vapour mixture.

The KSFI flame arrestors have specifically designed heat transfer characteristics for slow moving flames and low to medium pressure fronts (low to medium deflagration).

Inline flame arrestors can be installed either vertically or horizontally within a designated distance from the potential ignition source.

The standard flame cell is suitable for NEC group D or IEC 11A gases. Cells for other gas groups are available as additional extras.

The flame arrestors are available with either aluminium, nodular iron, cast steel, 304ss, 316ss and 316Lss housings. Iron and steel housings are supplied epoxy coated.

Sizes range from 15mm to 600mm.

Standard flanges are ANSI 150lb and other connections are available upon request.

Dimension Table

Size	1/2"	1"	1 1/2"	2"	3"	4"	6"	8"	10"	12"	14"	16"	20"	24"
DN	15	25	40	50	80	100	150	200	250	300	350	400	500	600
A	215	223	231	231	251	259	321	339	363	451	875	875	1050	1250
B	155	155	210	220	250	285	385	450	600	680	780	780	1015	1230

Standard connection: ANSI 150lb flange. JIS or different connections available on request.

Maintenance

Periodic inspection and maintenance is required. The cell assembly can be removed for cleaning purposes. Cleaning can be accomplished by dipping the entire cell assembly into an appropriate solvent. Care should be taken not to damage the cell openings as such deformations hamper the flow through the cell. The gaskets should be inspected and replaced if necessary.

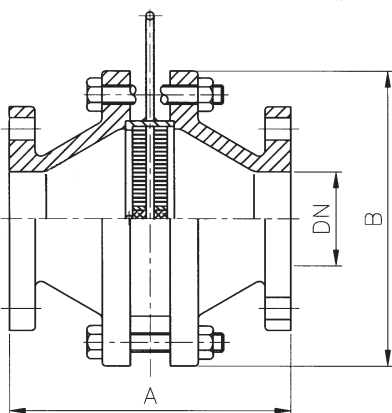

PO Box 154, 3/30-32 Peninsula Blvd, Seaford 3198

Phone: 03 9776 9477 Fax: 03 9776 9606

Email: pressure@ozemail.com.au www.pressuresystems.com.au

KSFI Type Flame Arrestor

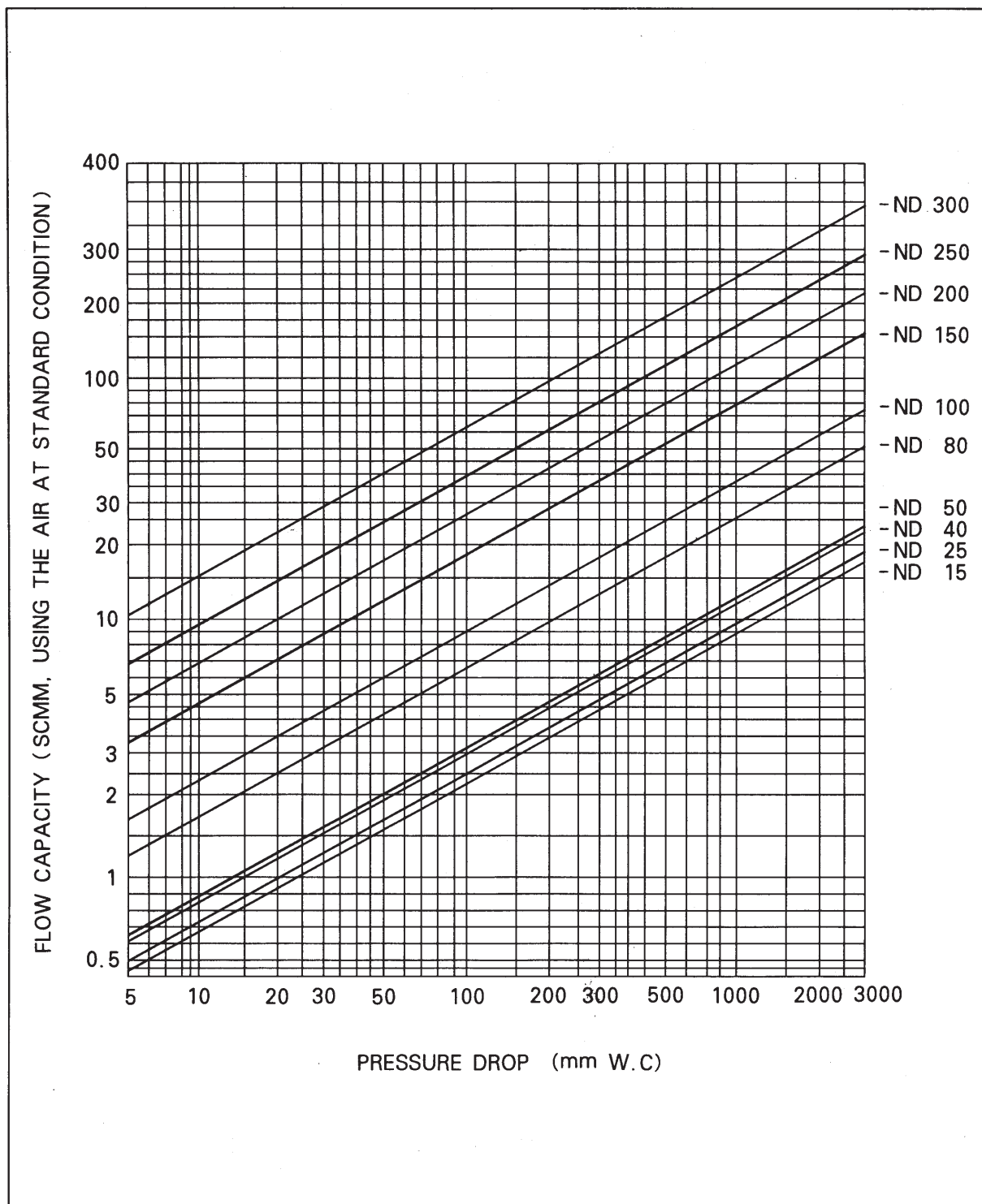

Flow capacity V in m³/min has been performed on equipment using air, specific gravity $g = 1.29\text{kg/m}^3$, at a temperature $T = 293^\circ\text{K}$ and at ambient pressure $P_{\text{amb}} = 1.033\text{ bar}$ to Korean KS standards.