

Type  
455, 456

# Vollhub-Feder-Sicherheitsventil PN 63-160 Full Lift Safety Valve PN 63-160 spring loaded

für Dämpfe, Gase und Flüssigkeiten  
for steam, gases and liquids

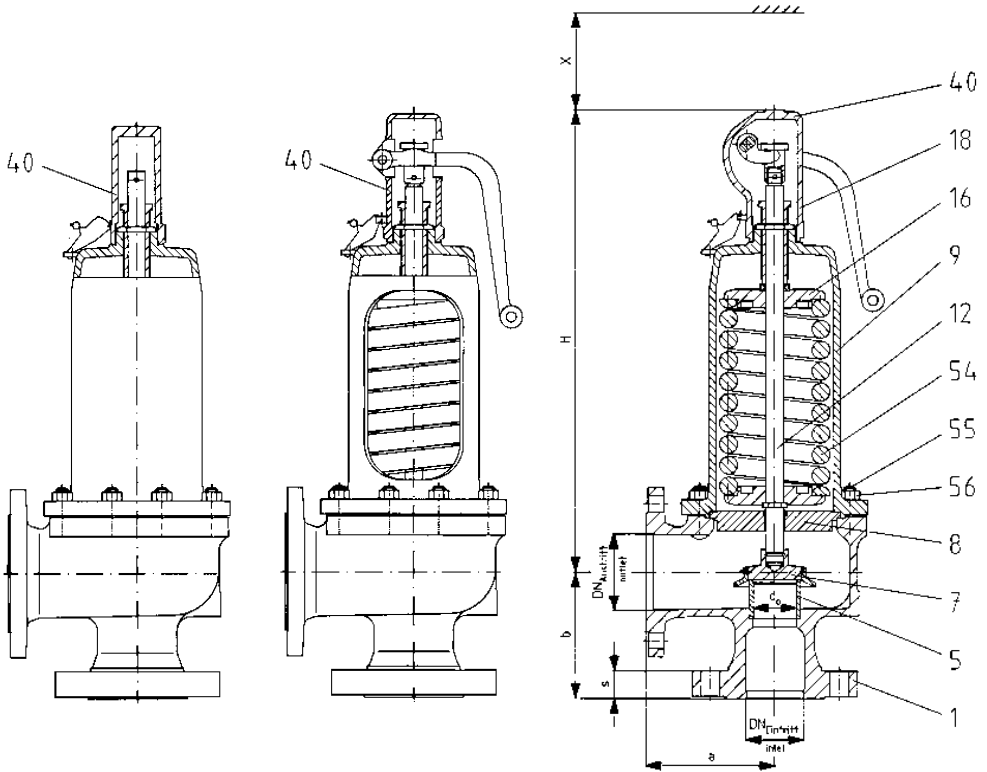

Type 456  
mit gasdichter Kappe H 2  
with gastight cap H 2

Type 455  
offene Federhaube mit  
Anlüftung H 3, Teller anlüftbar  
open bonnet  
lifting device H 3  
disc liftable

Type 456  
geschlossene Federhaube mit  
Anlüftung H 4 gasdicht, Teller anlüftbar  
closed bonnet  
lifting device H 4 gastight  
disc liftable

## Zusatzrüstungen

Edelstahl-Faltenbalg  
Teller mit Weichdichtung  
Heizmantel  
Entwässerungsbohrung  
Detailinformationen und weitere  
Zusatzrüstungen siehe Teil 13

## Accessories

Stainless steel bellows  
Disc with soft seal  
Heating jacket  
Drain hole

For detailed information and additional  
accessories refer to section 13

## Zulassungen / Approvals

	Dämpfe/Gase D/G Steam/Gases S/G		Flüssigkeiten F Liquids L	
	TÜV (AD-A2, TRD 421) Listennr./Approval number Ausflussziffer/Coefficient of discharge $\alpha d$ Öffnungscharakteristik/Opening characteristic	934 DN 25, 50, 100: 0,8 / DN 80: 0,75 Vollhub/Full lift		934 DN 25: 0,6 / DN 50: 0,54 / DN 80: 0,5 / DN 100: 0,56 Normal/Standard
ASME/NB Nr./No. Ausflussziffer/Coefficient of discharge K	1", 2", 4" 37066 0,798	3" 37088 0,754	1", 2", 4" 37077 0,572	3" 37099 0,479
Weitere / Others siehe Seite/refer to page 2/40-41	GOST, ISPEL, UDT			

Gehäusewerkstoff Body material			DN von bis from to	Flanschanschlüsse nach Flange connections acc. to		Temperatureinsatzbereich °C <sup>1)</sup> Temperature range °F <sup>1)</sup> Federhaube				Type	
DIN EN		ASME		DIN PN	ANSI B 16.5	DIN EN		ASME		Bonnet	
Werkstoffbezeichnung Material Designation	Werkstoff-Nr. Material No.		Eintr. Inlet	Austr. Outlet	von from	bis to	von from	bis to	geschl. closed	offen open	
GP 240 GH	1.0619	SA 216 WCB	25/1" 100/4"	63-160 40	#300-600 #150	-85/-121	+400/+752	-29/-20	+427/+800	4562	4552
GX5CrNiMoNb19-11-2	1.4581	SA 351CF10M	25/1" 100/4"	63-160 40	#300-600 #150	-85/-121	+400/+752	-184/-300	+300/+572	4564	-

<sup>1)</sup> Zwischen -10 °C und der niedrigsten, angegebenen Anwendungstemperatur ist gemäß AD-Merkblatt W10 zu verfahren.

<sup>1)</sup> Between -10 °C and lowest temperature indicated "AD-Merkblatt" W10 shall be taken into account.

## Artikelnummern / Article Numbers

Gehäusewerkstoff / Body material				Nennweite / Nominal Diameter										
				DIN EN	Werkstoff-Nr. Material No.	ASME	25	50	80	100				
Federhaube / Bonnet	geschlossen closed	GP 240 GH	1.0619	SA 216 WCB	4562	.601*	.602*	.603*	.604*					
		GX5 CrNiMoNb 19-11-2	1.4581 <sup>1)</sup>	SA 351CF10M	4564	.605*	.606*	.607*	.608*					
	offen open	GP 240 GH	1.0619	SA 216 WCB	4552	.6015	.6025	.6035	.6045					

\* Bitte hier gewünschte Ziffer für Kappe oder Anlüftung anfügen:

\* Please add number for the required cap or lifting device:

- 2 = Kappe H2
- 3 = Anlüftung H3 (offen)
- 4 = Anlüftung H4 (gasdicht)

- 2 = Cap H2
- 3 = Lifting device H3 (open)
- 4 = Lifting device H4 (gastight)

1) H3 ist bei diesem Werkstoff nicht lieferbar.

1) H3 is not available in this material.

Bei Bestellung bitte Artikelnummer entsprechend Bestellbeispiel im Teil 1, Ansprechdruck und ggf. Zusatzausrüstung (siehe Teil 13) angeben.

In event of order please state article number corresponding to the example for ordering in section 1, set pressure and if necessary, accessories (refer to section 13).

## Abmessungen, Druckbereiche, Gewichte / Dimensions, Pressure Ranges, Weights

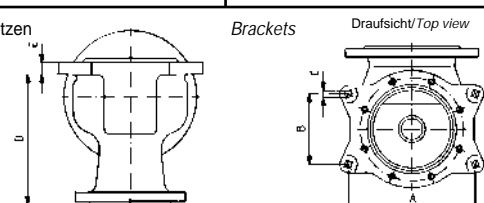
Nennweite, Ventilgröße		Nominal Diameter, Valve size		DN	-	25	50	80	100		
						1"	2"	3"	4"		
Nennweite, Austritt		Nominal Diameter, Outlet		DN	-	50	80	100	150		
						2"	3"	4"	6"		
Druckstufe Eintritt		Pressure rating Inlet				63-160					
		PN				#300-600					
Druckstufe Eintritt		Pressure rating Inlet				40					
Sonderausführung		Special Version				#150					
Druckstufe Austritt		Pressure rating Outlet		PN	-	40-63		40			
						#150-300		#150			
Druckstufe Austritt		Pressure rating Outlet		PN	-			63			
Sonderausführung		Special Version						#300			
Ansprechdruck	GS	Set pressure	CS	p	bar/bar g	100	100	77	77		
2)	GX	2)	SS	p	bar/bar g	100	65	51,5	49		
Engster Strömungsquerschnitt		Flow area		A <sub>0</sub>	mm <sup>2</sup>	314	1257	2827	4301		
Engster Strömungsdurchmesser		Flow diameter		d <sub>0</sub>	mm	20	40	60	74		
Schenkellänge	PN 40	Centre to face dim.	PN 40	a	mm	120	145	180	235		
bei Austrittsflansch	PN 63	for outlet flange	PN 63	a	mm	120	145	205	265		
Schenkellänge	Eintritt	Centre to face dim.	Inlet	b	mm	122	155	165	205		
Maß zur Bestimmung der Schraubenlänge		Used to find bolt length		s	mm	28	38	38	45		
Bauhöhe	H2	Height	H2	H	mm	355	481	594	791		
	H3 GS		H3 CS	H	mm	365	526	639	791		
	H4		H4	H	mm	371	529	642	791		
	H2 GX		H2 SS	H	mm	355	481	594	791		
	H4	H4	H	mm	363	529	642	791			
	mit Faltenbalg zus.		with bellows add.	H	mm	35	80	98	91		
Deckenfreiheit		Height clearance		x	mm	250	300	350	400		
Gewicht ohne Faltenbalg		Weight without bellows		-	kg	18	43	85	154		
mit Faltenbalg		with bellows		-	kg	20	46	102	185		
		Spannpratzen		Brackets		A	mm	140	184	278	364
						B	mm	-	110	160	210
						C	mm	Ø14	Ø14	Ø18	Ø18
						D	mm	149	194	225	288
						E	mm	18	18	27	32

2) Höhere Ansprechdrücke auf Anfrage möglich. / On request higher set pressures are possible.

## Werkstoffe / Materials

Pos. Item	Bauteile	Parts	4552/4562		4564	
			GS	CS	Korrosionsfest corrosion resistant	
1	Gehäuse	Body	GP 240 GH	1.0619	GX5 Cr Ni Mo Nb 19-11-2	1.4581
5	Sitz	Seat	X 2 Cr Ni Mo 17-12-2			1.4404
7	Teller	Disc	X 39 Cr Mo 17-1	1.4122	X 2 Cr Ni Mo 17-12-2	1.4404
8	Führungsscheibe mit Buchse	Guide with bush	C35/GGG-40 X 14 Cr Mo S 17 tenifer	1.0501/0.7040 1.4104 tenifer	X 2 Cr Ni Mo 17-12-2	1.4404
9	Federhaube	Bonnet	geschl./closed: GGG 40.3 (GP 240 GH) offen/open: GGG 40 (GP 240 GH)	0.7043 (1.0619) 0.7040 (1.0619)	GX5 Cr Ni Mo 19-11-2 X 2 Cr Ni Mo 17-12-2 X 6 Cr Ni Mo Ti 17-12-2	1.4408 1.4404 1.4571
12	Spindel	Spindle	X 2 Cr Ni Mo 17-12-2 tenifer			1.4404 tenifer
16	Federteller	Spring plate	11 S Mn Pb 30/X 2 Cr Ni Mo 17-12-2	1.0718/1.4404	X 2 Cr Ni Mo 17-12-2	1.4404
18	Druckschraube mit Buchse	Adjusting screw with bush	X 14 Cr Mo S 17 PTFE	1.4104 PTFE	X 2 Cr Ni Mo 17-12-2 tenifer PTFE	1.4404 tenifer PTFE
54	Feder	Spring	54 Cr Si 6/51 Cr V 4/X 10 Cr Ni 18-8	1.7102/1.8159/1.4310	X 10 Cr Ni 18-8	1.4310
40	Kappe H 2 Anlüftung H 3 Anlüftung H 4	Cap H 2 Lifting device H 3 Lifting device H 4	11 S Mn Pb 30/GGG 40.3 GGG-40 GGG-40	1.0718/0.7043 0.7040 0.7040	X 2 Cr Ni Mo 17-12-2 GX5 Cr Ni Mo 19-11-2	1.4404 1.4408
55/ 56	Stiftschraube und Mutter	Bolt and nut	A 4-70/A 4			1.4401/1.4401

### Zuerkannte Ausflussziffer $\alpha_d$ / Coefficient of Discharge $\alpha_d$

Diagramm 1

$$\alpha_d = f(h/d_0)$$

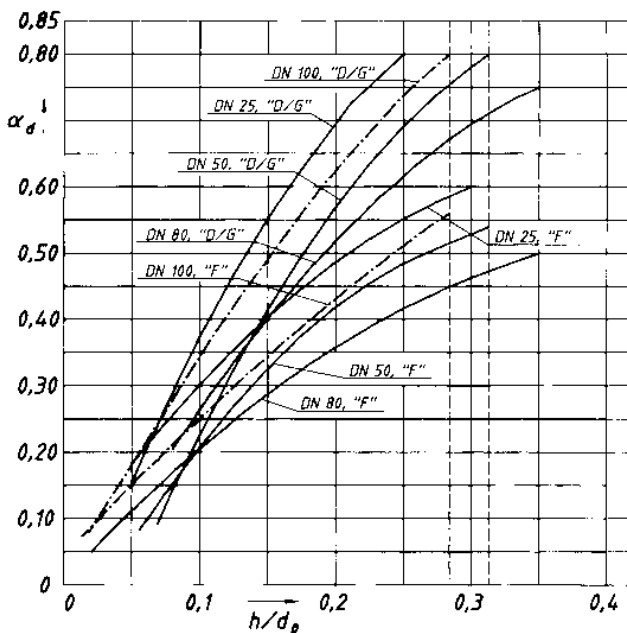

$h$  = Hub (mm)  
 $d_0$  = engster Strömungsdurchmesser (mm)  
 $p_{a0}$  = Gegendruck, absolut (bar)  
 $p_0$  = Ansprechdruck, absolut (bar)

Diagramm 2

$$\alpha_d = f(p_{a0}/p_0)$$

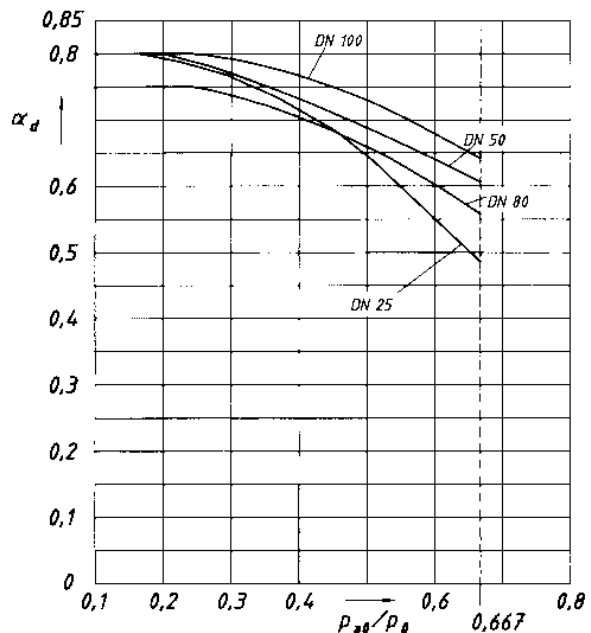

$h$  = Lift (mm)  
 $d_0$  = Flow diameter (mm)  
 $p_{a0}$  = Back pressure abs. (bar)  
 $p_0$  = Set pressure abs. (bar)

# Type 455, 456

Leistungstabelle										Discharge Capacities									
Berechnungen aus VALVESTAR® 6.2.50										Calculations from VALVESTAR® 6.2.50									
Berechnung entsprechend DIN 3320, AD2000-Merkblatt A2, TRD 421										Calculations of mass flow according to DIN 3320, AD2000-Merkblatt A2, TRD 421									
p	Ansprechüberdruck									Set pressure			bar g						
I	Sattdampf									Saturated steam			kg/h						
II	Luft bei 0°C und 1013 mbar									Air at 0°C and 1013 mbar			m <sup>3</sup> /h						
III	Wasser bei 20°C									Water at 20°C			10 <sup>3</sup> kg/h						
DN	25			50			80			100									
d <sub>0</sub> (mm)	20			40			60			74									
p	I	II	III	I	II	III	I	II	III	I	II	III							
2,5	501	610	15,9	2031	2471	57,2	4391	5343	119	7131	8676	203							
5	900	1112	22,5	3600	4450	80,9	7593	9386	169	12320	15229	287							
10	1632	2054	31,8	6530	8215	114	13774	17329	238	22348	28116	406							
15	2359	2995	38,9	9434	11980	140	19900	25271	292	32288	41002	498							
20	3091	3936	45,0	12363	15745	162	26078	33213	337	42312	53889	575							
25	3816	4878	50,3	15264	19511	181	32197	41155	377	52241	66775	642							
30	4555	5819	55,1	18219	23276	198	38431	49098	413	62356	79662	704							
35	5285	6760	59,5	21140	27041	214	44591	57040	446	72350	92548	760							
40	6035	7702	63,6	24138	30806	229	50917	64982	477	82614	105435	813							
45	6792	8643	67,5	27167	34572	243	57306	72924	506	92981	118321	862							
50	7557	9584	71,1	30230	38337	256	63765	80867	533	103461	131208	909							
55	8308	10525	74,6	33233	42102	268	70101	88809	559	113740	144094	953							
60	9090	11467	77,9	36360	45867	280	76697	96751	584	124442	156980	995							
65	9882	12408	81,1	39528	49632	292	83379	104693	608	135284	169867	1036							
70	10685	13349	84,1	42739	53398	303	90153	112636	631	146276	182753	1075							
75	11467	14291	87,1	45866	57163	313		120578	653	156977	195640	1113							
80	12291	15232	89,9	49165	60928	324		128520	675		208526	1149							
85	13129	16173	92,7	52517	64693	334		136462	695		221413	1185							
90	13981	17115	95,4	55925	68459	343		144405	715		234299	1219							
95	14849	18056	98,0	59395	72224	353		152347	735		247186	1252							
100	15687	18997	101	62749	75989	362		160289	754		260072	1285							

Leistungstabelle										Discharge Capacities								
Berechnungen aus VALVESTAR® 6.2.50										Calculations from VALVESTAR® 6.2.50								
Berechnung entsprechend ASME Boiler and Pressure Vessel Code, Sec. VIII, Div. 1 mit 10 % Drucksteigerung und der zuerkannten Ausflussziffer K. Leistungen unterhalb 30 psig sind mit 3 psi Drucksteigerung berechnet.										Calculation of mass flow according to ASME Boiler and Pressure Vessel Code, Sec. VIII, Div. 1 at 10 % overpressure and with certified coefficient of discharge K. Capacities below 30 psig are calculated including 3 psi overpressure.								
p	Ansprechüberdruck									Set pressure			psig					
I	Sattdampf, Abblasen gegen Atmosphärendruck (14,7 psi)									Saturated Steam, valve discharging to atmospheric pressure (14,7 psi)			lb/h					
II	Luft bei 60°F, Abblasen gegen Atmosphärendruck (14,7 psi)									Air at 60°F, valve discharging to atmospheric pressure (14,7 psi)			SCFM					
III	Wasser bei 70°F									Water at 70°F			U.S. gallons per minute					
DN	25			50			80			100								
	1 x 2			2 x 3			3 x 4			4 x 6								
d <sub>0</sub> (mm)	20			40			60			74								
p	I	II	III	I	II	III	I	II	III	I	II	III	I	II	III	I	II	III
40	1171	417	70,2	4684	1669	281	9957	3547	529	16030	5710	961						
60	1611	574	86,0	6445	2296	344	13701	4881	648	22057	7857	1177						
80	2051	731	99,3	8206	2923	397	17445	6215	748	28085	10004	1359						
100	2492	888	111	9967	3551	444	21189	7549	837	34112	12151	1520						
120	2932	1045	122	11728	4178	486	24933	8883	917	40139	14298	1665						
140	3372	1201	131	13489	4806	525	28677	10216	990	46166	16445	1798						
160	3813	1358	140	15250	5433	562	32421	11550	1058	52194	18592	1922						
180	4253	1515	149	17011	6060	596	36165	12884	1123	58221	20738	2039						
200	4693	1672	157	18772	6688	628	39909	14218	1183	64248	22885	2149						
220	5133	1829	165	20533	7315	659	43653	15552	1241	70275	25032	2254						
240	5574	1986	172	22294	7943	688	47397	16885	1296	76303	27179	2354						
260	6014	2142	179	24055	8570	716	51140	18219	1349	82330	29326	2450						
280	6454	2299	186	25817	9197	743	54884	19553	1400	88357	31473	2543						
300	6894	2456	192	27578	9825	769	58628	20887	1449	94384	33620	2632						
350	7995	2848	208	31980	11393	831	67988	24221	1565	109452	38987	2843						
400	9096	3240	222	36383	12962	888	77348	27556	1673	124520	44355	3039						
450	10196	3633	236	40786	14530	942	86708	30890	1775	139589	49722	3224						
500	11297	4025	248	45188	16099	993	96067	34225	1871	154657	55089	3398						
550	12398	4417	260	49591	17667	1041	105427	37559	1962	169725	60457	3564						
600	13498	4809	272	53994	19236	1088	114787	40894	2050	184793	65824	3722						
650	14599	5201	283	58396	20804	1132	124147	44228	2133	199861	71191	3874						
700	15700	5593	294	62799	22373	1175	133507	47563	2214	214929	76559	4021						
750	16800	5985	304	67202	23941	1216	142866	50897	2291	229997	81926	4162						
800	17901	6377	314	71604	25510	1256	152226	54232	2367	245065	87293	4298						
850	19002	6770	324	76007	27078	1295	161586	57567	2439	260133	92661	4430						
900	20102	7162	333	80410	28647	1332	170946	60901	2510	275202	98028	4559						
950	21203	7554	342	84812	30215	1369	180306	64236	2579	290270	103395	4684						
1000	22304	7946	351	89215	31784	1404	189665	67570	2646	305338	108763	4806						
1100	24505	8730	368	98020	34921	1473		74239	2775		119497	5040						
1200	26706	9514	385	106825	38058	1538		80908	2899									
1300	28908	10299	400	115631	41195	1601												
1400	31065	11083	415	124260	44332	1662												
1500		11867	430		47468	1720												