

Type 484

Clean-Service-Feder-Sicherheitsventil mit totfraumfreiem Behälteranschluss Clean Service Safety Valve spring loaded, vessel connection, dead space free für Dämpfe, Gase und Flüssigkeiten for steam, gases and liquids

Anschlüsse

siehe Seite 12/01 und 12/02
Waagerechter Einbau möglich

Connections

refer to page 12/01 and 12/02
Horizontal installation possible

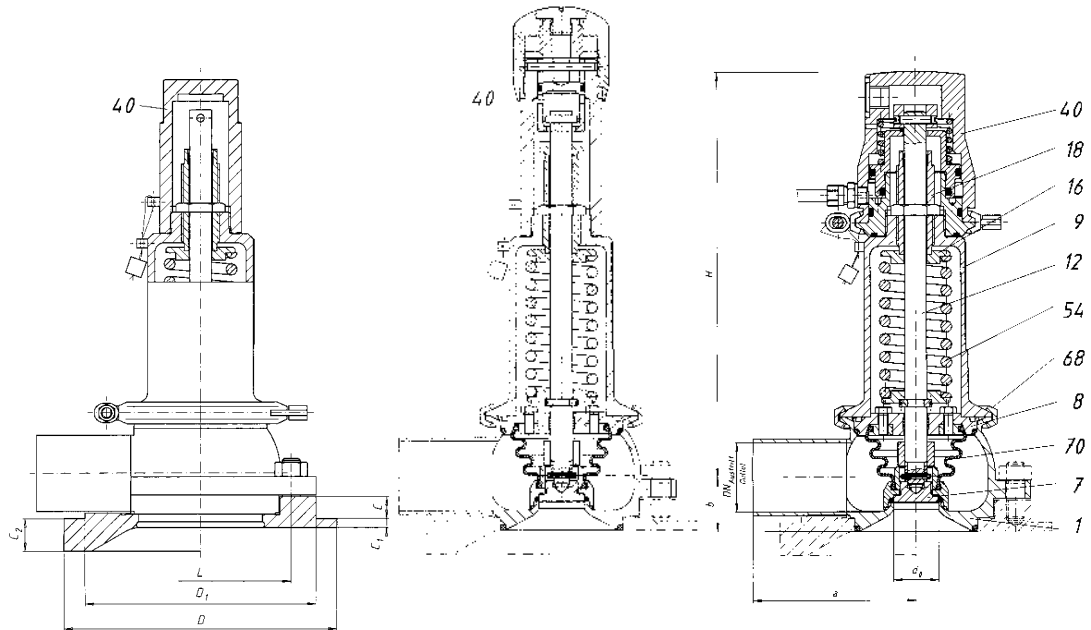

Type 484
mit gasdichter Kappe H2
Austritt: Schweißanschluss – 00
with gastight cap H2
Outlet: welding connection – 00

Type 484
mit Anlüftung H4, gasdicht,
Teller anlüftbar
Austritt: Schweißanschluss – 00
with lifting device H4, gastight,
disc liftable
Outlet: welding connection – 00

Type 484
mit pneumatischer Anlüftung H8, gasdicht,
Teller anlüftbar
Austritt: Schweißanschluss – 00
with lifting device H8, gastight,
disc liftable
Outlet: welding connection – 00

Zulassungen / Approvals

EG-Bauteilprüfnr./EC-type examination no. 07 202 0111 Z00080/20	Dämpfe/Gase D/G Steam/Gases S/G			Flüssigkeiten F Liquids L	
	TÜV (AD-A2, TRD 421, VdTÜV SV 100) Listennr./Approval number Ausflussziffer/Coefficient of discharge αd Öffnungscharakteristik/Opening characteristic	1047 d ₀ 13 : 0,60 d ₀ 25 : 0,41 Normal/Standard			1047 d ₀ 13 : 0,40 d ₀ 25 : 0,28 Normal/Standard
ASME/NB (ASME Sec. VIII Div. 1) Nr./No. Nennsteigung = W/P / Rated Slope = W/P	M37145 d ₀ 13: 1,96 SCFM/PSIA	M37167 d ₀ 25: 4,96 SCFM/PSIA	M37156 d ₀ 13: 2,96 GPM/√PSID	M37178 d ₀ 25: 7,46 GPM/√PSIA	
Weitere / Others siehe Seite / refer to page 2/40-41	DGR/PED UDT	DIN GOST ISPESL	TMB		

Gehäusewerkstoff Body material			DN				Temperatureinsatzgrenze °C Temperature range °F				Druckeinsatzbereich bar pressure range psig	
DIN EN		ASME	von from	bis to	von from	bis to	DIN EN		ASME		von from	bis to
Werkstoffbezeichnung Material Designation	Werkstoff-Nr. Material No.											
X 2 CrNiMo 18-14-3	1.4435	SA 316L	25	40	1"	1 1/2"	-45/-49	150/302	-45/-49	150/302	0,1/1,5	16/232

Artikelnummern / Article Numbers

Nennweite, Ventilgröße nominal diameter, valve size	DN	–	25	40			
Artikelnummer article numbers	4844.	772*	773*				

* Bitte hier gewünschte Ziffer für Kappe oder Anlüftung anfügen:
2 = Kappe H2 4 = Anlüftung H4 8 = Anlüftung H8

* Please add number for the required cap or lifting device:
2 = Cap H2 4 = lifting device H4 8 = lifting device H8

Änderungen behalten wir uns vor.

Modifications reserved.

Artikelnummern Behälterflansche / Article Numbers vessel flanges

Nennweite	Nominal diameter	DN		25		40	
Behälterwanddicke	Vessel wall thickness	t	mm in.	≤ 5 ≤ 13/64	> 5 > 13/64	≤ 5 ≤ 13/64	> 5 > 13/64
Artikelnummer	Article number			5034.0980	5034.0981	5034.0982	5034.0983

Abmessungen, Druckbereiche, Gewichte / Dimensions, Pressure Ranges, Weights

Nennweite, Ventilgröße		Nominal Diameter, Valve size		DN	–	25	40	
Nennweite, Eintritt		Nominal diameter, inlet		DN	–	25	40	
Nennweite, Austritt		Nominal diameter, outlet		DN	–	25	40	
Nennweite, Eintritt		Nominal diameter, inlet		NPS	–	–	–	
Nennweite, Austritt		Nominal diameter, outlet		NPS	–	1 1/2"	2"	
Druckstufe Eintritt		Pressure rating inlet		PN	–	16	16	
Druckstufe Austritt		Pressure rating outlet		PN	–	16	16	
Druckstufe Eintritt		Pressure rating inlet		–	–	# 150	# 150	
Druckstufe Austritt		Pressure rating outlet		–	–	# 150	# 150	
Max. Ansprechdruck		Max. Set pressure		p	bar	16	16	
				p	psig	232	232	
Engster Strömungsquerschnitt		Flow area		A ₀	mm ²	133	491	
Engster Strömungsdurchmesser		Flow diameter		A ₀	sq. in.	0,206	0,761	
				d ₀	mm	13	25	
				d ₀	in.	0,512	0,985	
Eintrittsschenkellänge/inlet centre to face dimension								
mit Behälteranschluss		with vessel connection		b	mm	18,5	25	
				b	in.	23/32	31/32	
Austrittsschenkellänge/outlet centre to face dimension								
Schlüssel/code	nach/acc. to	Anschlussarmatur		connection				
00	DIN 11850	Schweißanschluss		welding connection		a	mm	
				a	in.	80	90	
						a	3 5/32	
						3 17/32		
Behälterwanddicke		Vessel wall thickness		t	mm in.	≤ 5 ≤ 13/64	> 5 > 13/64	
Flanschdicke		Flange thickness		C _{1,2}	mm in.	5 13/64	18 45/64	
Abstand		Distance		C	mm in.	12 15/32		
Außendurchmesser		Outside diameter		D	mm in.	130 5 1/8	150 5 29/32	
Durchmesser		Diameter		D ₁	mm in.	110 4 21/64	127 5	
Durchmesser		Diameter		L	mm in.	90 3 35/64	110 4 21/64	
Bauhöhe		height		H ₂	H	mm	151	
				H ₂	H	in.	5 15/16	217
				H ₄	H	mm	173	8 17/32
				H ₄	H	in.	6 13/16	253
				H ₈	H	mm	187	9 31/32
				H ₈	H	in.	7 3/8	225
Gewicht		weight		-	kg	3,0	4,0	

Hinweise:

Die Montage oder Demontage des Tellers der Type 484 DN 40 erfordert ein Montage-Werkzeug.

Remarks:

The assembly or disassembly of the disc type 484 DN 40 requires an assembly tool.

Werkstoffe / Materials

Pos. Item	Bauteile	Parts	4844	
			korrosionsfest/corrosion resistant	ASME
			Werkstoff Nr./material no.	
1	Gehäuse	body	1.4435	SA 316 L
5	Sitz	seat		
7	Teller mit Weichdichtung	disc with soft seal	1.4435	SA 316 L
8	Führungsscheibe mit Buchse	guide with bush	1.4435	EPDM – FDA 316 L
9	Federhaube	bonnet	1.4404	PTFE + Glas 15 % 316 L
12	Spindel	spindle		
16	Federteller	spring plate		
18	Druckschraube mit Buchse	adjusting screw with bush	1.4404	PTFE + Glas 15 % 316 L
54	Feder	spring	1.4310	302
40	Kappe H2 Anlüftung H4 Pneumat. Anlüftung H8	cap H2 lifting device H4 pneum. lifting device H8	1.4404	316 L
68	Klappiring	clamp	1.4401	316
70	Faltenbalg	bellows	EPDM – FDA	
48	Behälterflansch	vessel flange	1.4435	316 L
56	Sechskantmutter	hexagon nut	1.4404	316 L
92	Stiftschraube	stud	1.4404	316 L

Zuerkannte Ausflussziffer α_d / Coefficient of Discharge α_d

Diagramm 1
 $\alpha_d = f(h/d_o)$

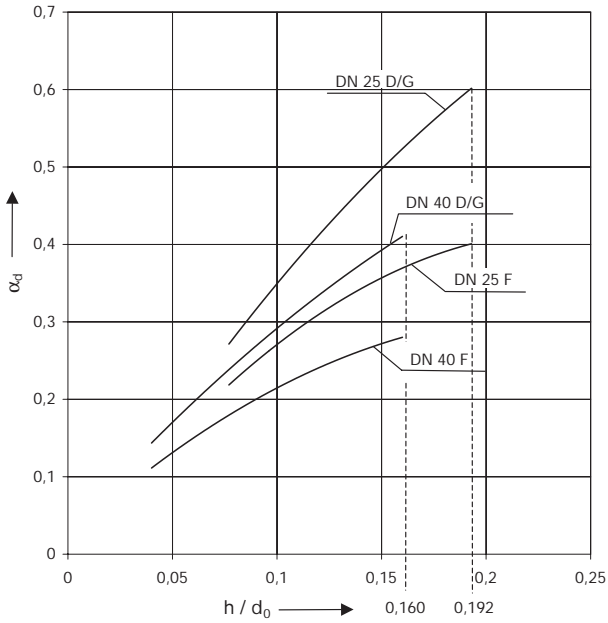

h = Hub (mm)
 d_o = engster Strömungsdurchmesser (mm)
 p_{ao} = Gegendruck, bar (abs.)
 p_o = Ansprechdruck, bar (abs.)

Diagramm 2
 $\alpha_d = f(p_{ao}/p_o)$

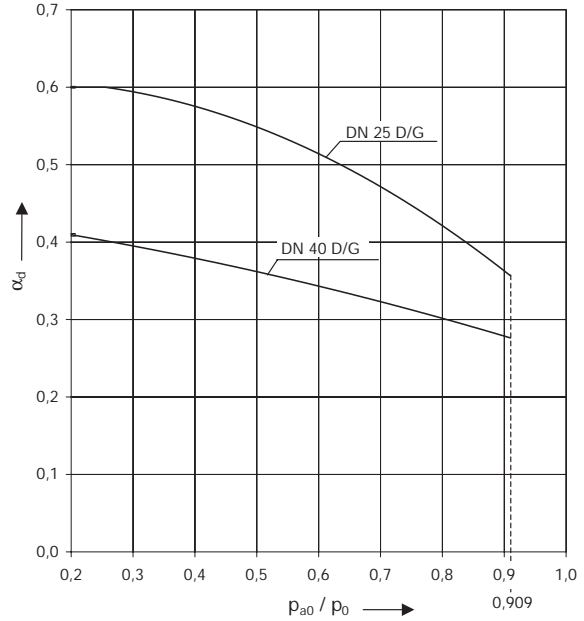

h = Lift (mm)
 d_o = Flow diameter (mm)
 p_{ao} = Back pressure bar (abs.)
 p_o = Set pressure bar (abs.)

Type 484

Leistungstabelle/Discharge capacities

Berechnungen aus VALVESTAR® 6.2.50		Calculations from VALVESTAR® 6.2.50	
Berechnung entsprechend DIN 3320, AD2000-Merkblatt A2, TRD 421		Calculation of mass flow according to DIN 3320, AD2000-Merkblatt A2, TRD 421	
p	Ansprechüberdruck	Set pressure	bar g
I	Sattdampf	Saturated steam	kg/h
II	Luft 0°C und 1013 mbar	Air at 0°C and 1013 mbar	m³/h
III	Wasser bei 20°C	Water at 20°C	10³kg/h





DN	25			40		
	I	II	III	I	II	III
d_o (mm)	13			25		
p	I	II	III	I	II	III
0,2	35	40	1,48	94	109	3,83
0,5	58	68	2,09	143	168	5,42
1	86	103	2,83	212	253	7,33
2	139	168	4,01	337	406	10,4
3	191	233	4,91	482	589	12,7
4	238	293	5,66	602	740	14,7
5	285	353	6,33	721	891	16,4
6	332	412	6,94	839	1042	18,0
7	378	472	7,49	955	1192	19,4
8	424	531	8,01	1072	1343	20,7
9	471	591	8,50	1190	1494	22,0
10	517	651	8,96	1307	1645	23,2
12	610	770	9,81	1542	1946	25,4
14	701	889	10,6	1772	2248	27,4
16	794	1009	11,3	2006	2549	29,3

Berechnungen aus VALVESTAR® 6.2.50		Calculations from VALVESTAR® 6.2.50	
Berechnung entsprechend ASME Boiler and Pressure Vessel Code, Sec. VIII, Div. 1 mit 10% Drucksteigerung und der zuerkannten Ausflussziffer K. Leistungen unterhalb 30 psig sind mit 3 psi Drucksteigerung berechnet.		Calculation of mass flow according to ASME Boiler and Pressure Vessel Code, Sec. VIII, Div. 1 at 10% overpressure and with certified coefficient of discharge K. Capacities below 30 psig are calculated including 3 psi overpressure.	
p	Ansprechüberdruck	Set pressure	psig
I	Sattdampf, Abblasen gegen Atmosphärendruck (14,7 psi)	Saturated Steam, valve discharging to atmospheric pressure (14,7 psi)	lb/h
II	Luft bei 60°F, Abblasen gegen Atmosphärendruck (14,7 psi)	Air at 60°F, valve discharging to atmospheric pressure (14,7 psi)	SCFM
III	Wasser bei 70°C	Water at 70°F	U.S. gallons per minute

DN	25			40		
	I	II	III	I	II	III
d_o (mm)	13			25		
p	I	II	III	I	II	III
15	179	64	12,6	455	162	31,7
20	207	74	14,2	525	187	35,8
40	323	115	19,7	819	292	49,5
60	444	159	24,1	1126	401	60,6
80	566	202	27,8	1434	511	70,0
100	687	245	31,1	1742	621	78,2
120	809	288	34,1	2050	730	85,7
140	930	332	36,8	2357	840	92,6
160	1052	375	39,4	2665	950	99,0
180	1173	418	41,8	2973	1059	105
200	1295	462	44,0	3281	1169	111
220	1416	505	46,2	3588	1278	116
230	1477	527	47,2	3742	1333	119

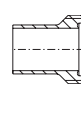
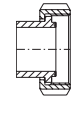
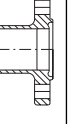
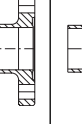
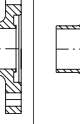
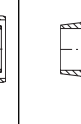
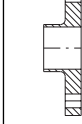
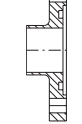
Anschlüsse Connections

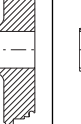
Type
481-488

	Schlüssel code	Anschlussarmatur	connection	nach/acc. to	481			483			484			485			448 + 488								
					25	40	E A E	25	40	E A E	25	40	E A E	25	40	E A E	25	40	E A E	25	40	50	65	80	100
					E	A	E	E	A	E	A	E	A	E	A	E	A	E	A	E	A	E	A	E	A
	GD	Steril Gewindestutzen	sterile thread	Neumo	x	x	x	x	x	x	x	x	x	x	x	x	x	x	x	x	x	x	x	x	
	BD	Steril Bundstutzen mit Nutmutter	sterile-clamp and nut	Neumo	x	x	x	x	x	x	x	x	x	x	x	x	x	x	x	x	x	x	x	x	
	NF	Aseptik-Nutfiansch	aseptic-flange, female	DIN 11864 T2 Form A	-	x	x	x	x	x	x	x	x	x	x	x	x	x	x	x	x	x	x	x	
	BF	Aseptik-Bundfiansch	aseptic-flange, male	DIN 11864 T2 Form A	-	x	x	x	x	x	x	x	x	x	x	x	x	x	x	x	x	x	x	x	
	NG	Aseptik-Nutfiansch	aseptic-flange, groove	DIN 11864 T2 Form B	-	x	x	x	x	x	x	x	x	x	x	x	x	x	x	x	x	x	x	x	
	BG	Aseptik-Bundfiansch	aseptic-flange, tongue	DIN 11864 T2 Form B	-	x	x	x	x	x	x	x	x	x	x	x	x	x	x	x	x	x	x	x	
	TN	Varivent-Nutfiansch	Varivent-flange, groove	Tuchenhagen	-	x	x	x	x	x	x	x	x	x	x	x	x	x	x	x	x	x	x	x	
	AF	APV-FG1 Glatfiansch PN 10	APV-FG1 flange, flat face PN 10	APV	-	x	x	x	x	x	x	x	x	x	x	x	x	x	x	x	x	x	x	x	
	AN	APV-FN1 Nutfiansch PN 10	APV-FN1 flange, groove PN 10	APV	-	x	x	x	x	x	x	x	x	x	x	x	x	x	x	x	x	x	x	x	
	VG	Variventanschluss DN 32/XX	Varivent connection DN 32/XX	Tuchenhagen	-	-	-	-	-	-	-	-	-	-	-	-	-	-	-	-	-	-	-	-	
	VH	Variventanschluss DN 50/XX	Varivent connection DN 50/XX	Tuchenhagen	-	-	-	-	-	-	-	-	-	-	-	-	-	-	-	-	-	-	-	-	
	VC	Variventanschluss DN 80/XX	Varivent Connection DN 80/XX	Tuchenhagen	-	-	-	-	-	-	-	-	-	-	-	-	-	-	-	-	-	-	-	-	
	VE	Variventanschluss DN 127/XX	Varivent connection DN 127/XX	Tuchenhagen	-	-	-	-	-	-	-	-	-	-	-	-	-	-	-	-	-	-	-	-	

Bestellung How to order

**Type
481 – 488**

Bestellbeispiel/example for Ordering:

Type/type 483	• Nennweite	• size	DN 25/NPS 1"
	• pneumatische Anlüftung	• <i>pneumatic lifting device</i>	H8
	• Ansprechdruck	• <i>set pressure</i>	10,5 bar
	• Eintritt: Kegelstutzen mit Überwurfmutter	• <i>inlet: aseptic-clamp and nut</i>	DIN 11851
	• Austritt: Gewindestutzen	• <i>outlet: thread</i>	DIN 11851

Die Bestellnummer der LESER Clean Service-Sicherheitsventile wird wie folgt gebildet:

The ordering number of the LESER clean service safety valves is formed as follows:

Artikelnummern / Article Numbers

Nennweite, Ventilgröße	<i>nominal diameter, valve size</i>	DN	–	25	40				
Nennweite, Eintritt	<i>nominal diameter, inlet</i>	DN	–	1"	1 1/2"				
Nennweite, Austritt	<i>nominal diameter, outlet</i>	DN	–	1"	1 1/2"				
Artikelnummer	<i>article numbers</i>			4834.	770*	771*			

4 8 3 4 . 7 7 0 8 – 1 0 , 5 bar – KO GO

Bestellnummer/ordering number

